

I.T.I.S. G. Marconi – Cagliari

Piastra di sostegno
vista frontale

Tav.
1 p

Scala: 1:1

Giorgio Demurtas – Classe 3Bea

19/05/03

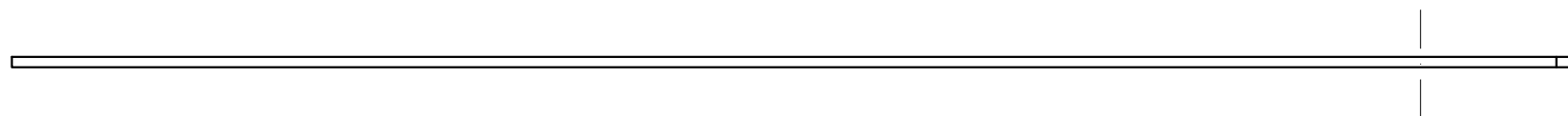
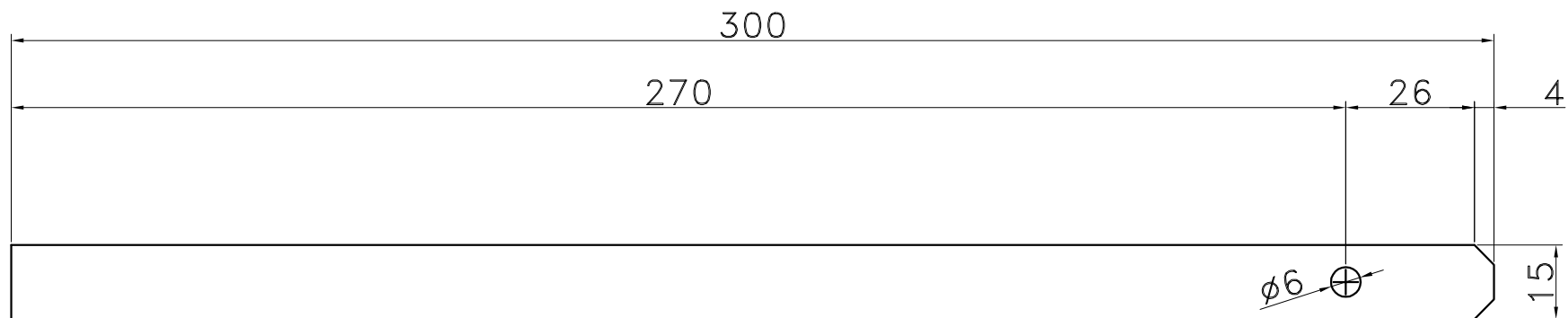

I.T.I.S. G. Marconi – Cagliari	
sbarra	Tav. 2p
	Scala: 1:1
Giorgio Demurtas – Classe 3Bea	19/05/03

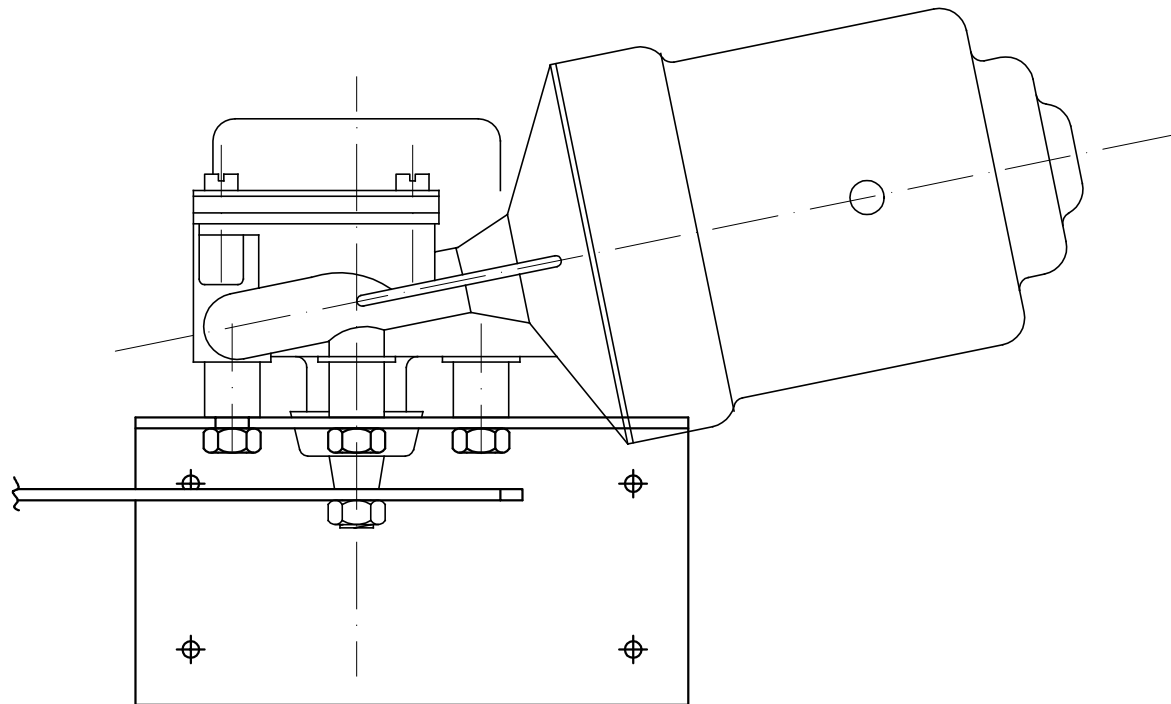

I.T.I.S. G. Marconi – Cagliari

Piastra di sostegno
vista dall'alto

Giorgio Demurtas – Classe 3Bea

Tav. 3p

Scala: 1:1

19/05/03

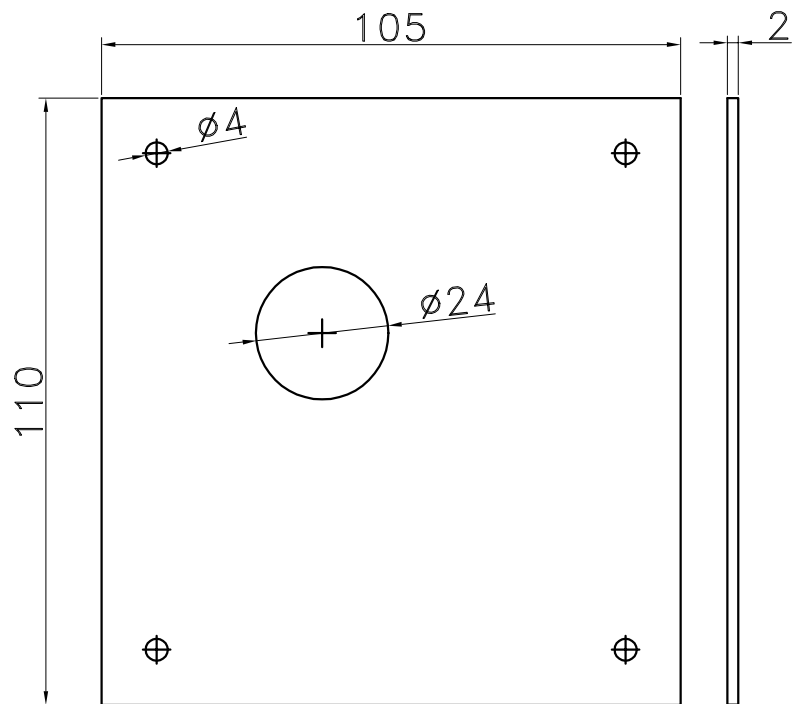

I.T.I.S. G. Marconi – Cagliari

Piastra aggiuntiva
per sostegno finecorsa

Tav. **4p**

Scala: 1:1

Giorgio Demurtas – Classe 3Bea

25/05/03

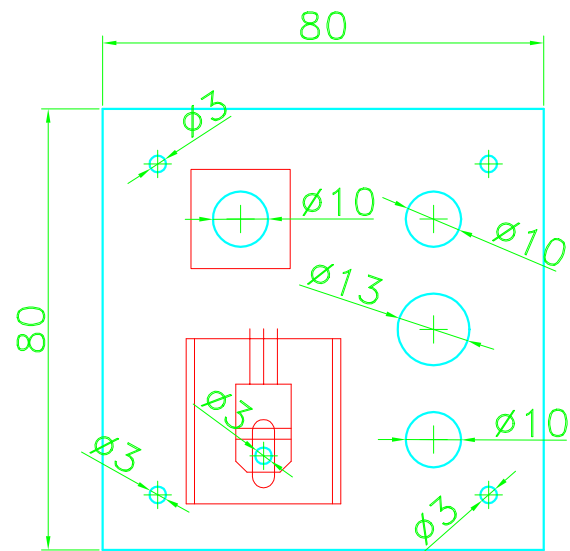
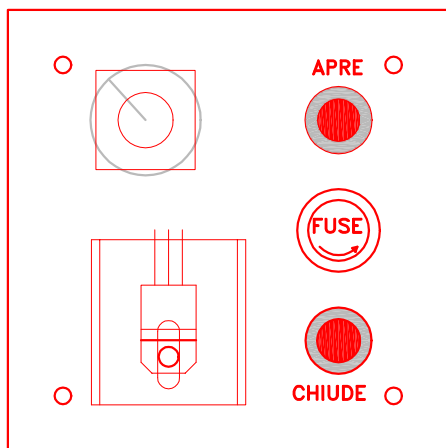

I.T.I.S. G. Marconi – Cagliari

Pannello di regolazione velocità
e comandi manuali d'emergenza

Tav. 5p

Scala: 1:1

Giorgio Demurtas – Classe 3Bea

25/05/03